



## EXTRUDED ALUMINUM FACEPLATE ASSEMBLIES WITH RETENTION FLANGE - uTCA.0 REL.1.0 COMPLIANT

### SPECIFICATIONS

- FACEPLATE - Extruded Aluminum with Retention Flanges
- FINISH - Trivalent Chromate
- M3 CAPTIVE SCREWS - Stainless Steel and Zinc Chromate over Steel.
- DUAL LIGHT PIPE - Polycarbonate
- LIGHT PIPE HOUSING - Zinc-Alloy with Electroless Nickel
- PCB SCREWS - Stainless Steel with Locking Patch
- HOT SWAP LATCH HANDLE - Zinc-Alloy and Stainless Steel with Powder Coated Handle
- EMI GASKETS - Fabric over Foam
- CUSTOM OVERLAY - 0.25mm Velvet Matte Polycarbonate
- SPECIFICATION COMPLIANCE - PICMG uTCA.0 Rel 1.0; UL94-V0; RoHS Compliant

### FEATURES

- INCREASED LOCKING SECURITY FOR USE IN ROUGH SERVICE.
- LIGHT WEIGHT, ROBUST ALUMINUM PROFILE
- SNAG-RESISTANT GASKET CURB ALSO ENHANCES EMI INTEGRITY
- OVERLAY GALLERY TO ENSURE CRISP AESTHETICS
- TAPERED LEAD-IN ON SIDE FLANGES TO GUARANTEE SMOOTH INSERTION
- 1.0 MM THICK FACE FOR ROBUST CONNECTOR RETENTION AND GROUNDING.
- CUSTOM I/O CUTOUPS INCLUDED
- MAXIMUM FACE AREA AVAILABLE FOR CONNECTOR CUTOUPS
- ALL FACEPLATE ASSEMBLIES AND PANEL COMBINATIONS ARE SUPPLIED AND READY TO ATTACH TO YOUR MODULE OR TO INSTALL DIRECTLY INTO YOUR uTCA SYSTEM.

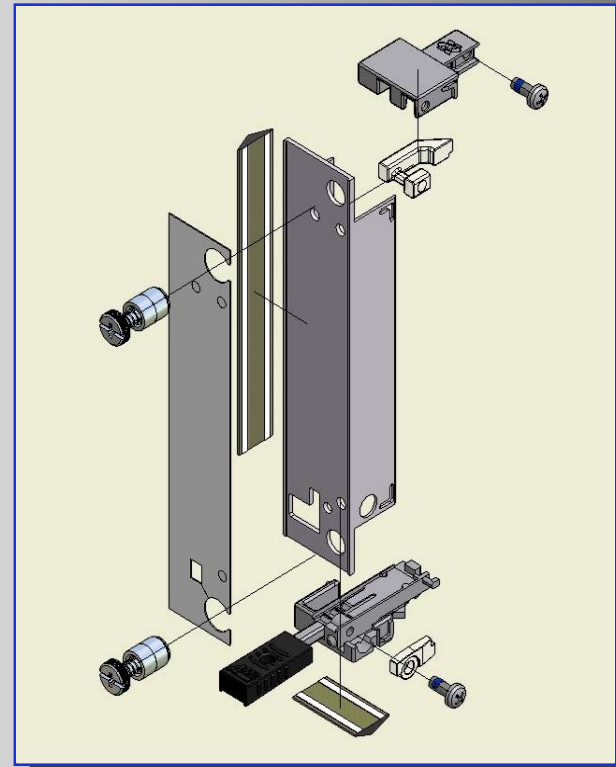
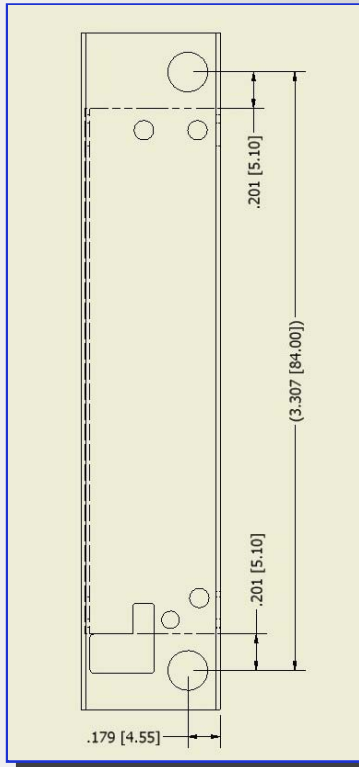

### AVAILABLE CONFIGURATIONS

- Compact, Mid-Size and Full-Size
- Single and Double Width
- With Custom I/O, Latch, and Light Pipes or with XTech's Full Range of Filler Panels and Air Baffles.

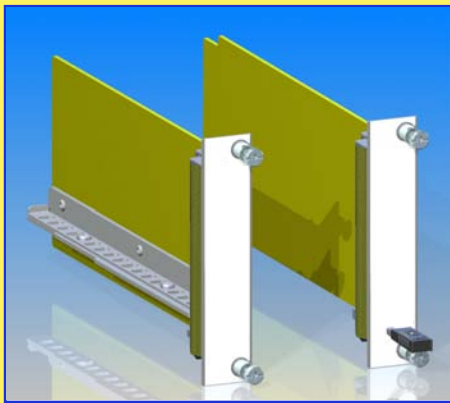

### SIZES AND PART NUMBERS

