



SPECIFICATIONS

- FACEPLATE - Extruded Aluminum
- FINISH - Trivalent Chromate
- EMI GASKETS - Fabric over Foam
- OVERLAY - 0.25mm Velvet Matte Polycarbonate
Standard Overlay comes in XTech Silver, Custom options available upon request.
- SPECIFICATION COMPLIANCE -
PICMG AMC.0, uTCA.0, UL94-V0, RoHS Compliant

FEATURES

- SIMPLE ASSEMBLY - ROBUST CONSTRUCTION
- LIGHT WEIGHT, EXTRUDED ALUMINUM PROFILE
- SNAG-RESISTANT GASKET CURB
- OVERLAY GALLERY TO ENSURE CRISP AESTHETICS
- ASSEMBLED AND READY TO ATTACH TO YOUR MODULE
- CAN BE USED WITH BOTH EXTRUDED ALUMINUM AND SHEET METAL FACEPLATES
- COMPATIBLE WITH AMC.O REL.1.0 AND 2.0 COMPONENTS.

TO ACCOMMODATE VARYING COMPONENT ENVELOPES, RETAINING CLIPS MAY BE RELOCATED ALONG CROSS HATCHED SURFACE.

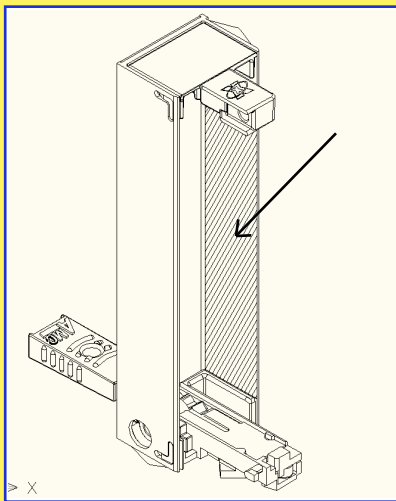

2HP EXTENDER CONVERT MID-SIZE AMC MODULES TO FULL-SIZE ENVELOPES

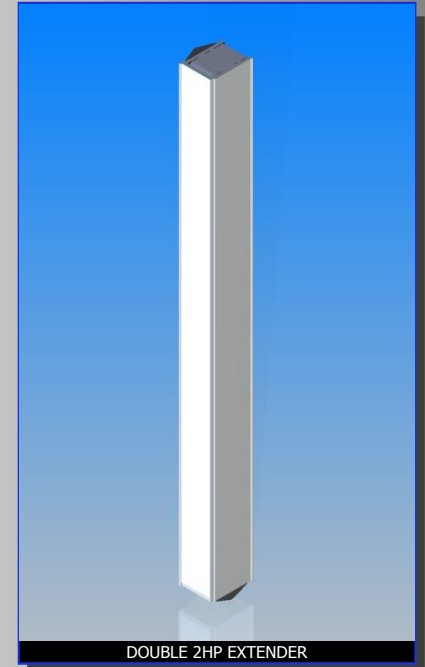
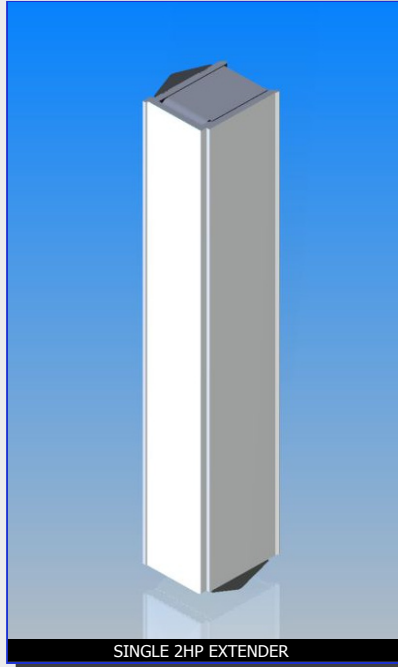

W	H	D	PART #	DESCRIPTION	H x W x D	QTY
			125432	Single 2HP Extender	73.8mm x 10.5mm x 13.6mm	10
			125434	Double 2HP Extender	148.8mm x 10.5mm x 13.6mm	10
EACH KIT INCLUDES:						
- 10 2HP EXTENDER PACKETS						
EACH PACKET INCLUDES:						
- Front Panel Assembly with Label and Foam Gaskets						
- 2 Clips						
- Instruction Sheet						

SHOWN WITH SHEET METAL AMC MODULE

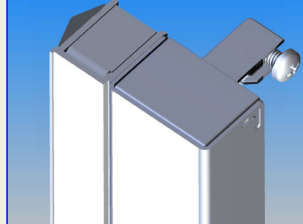

SHOWN WITH ALUMINUM AMC MODULE

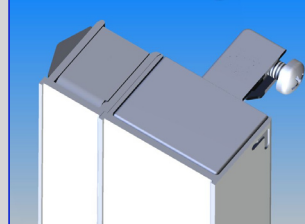

MODULE - COMPATIBLE WITH ALL AMC EJECTOR TYPES

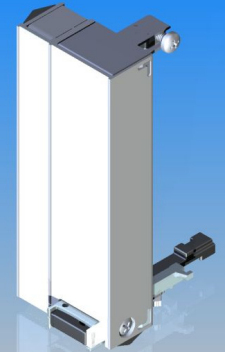

SHOWN WITH FLUSH EJECTOR

