



ALUMINUM SPECIFICATIONS

- FACEPLATE - Extruded Aluminum
- FINISH - Trivalent Chromate
- DUAL LIGHT PIPE - Polycarbonate
- LIGHT PIPE HOUSING - Zinc-Alloy with Electroless Nickel
- PCB SCREWS - Stainless Steel with Locking Patch
- HOT SWAP LATCH HANDLE - Zinc-Alloy and Stainless Steel with Powder Coated Handle
- EMI GASKETS - Fabric over Foam
- CUSTOM OVERLAY - 0.25mm Velvet Matte Polycarbonate
- SPECIFICATION COMPLIANCE - PICMG AMC.0 Rel 2.0; UL94-V0; RoHS Compliant

FEATURES

- LIGHT WEIGHT, EXTRUDED ALUMINUM PROFILE
- SNAG-RESISTANT GASKET CURB ALSO ENHANCES EMI INTEGRITY
- OVERLAY GALLERY TO ENSURE CRISP AESTHETICS
- TAPERED LEAD-IN ON SIDE FLANGES TO GUARANTEE SMOOTH INSERTION
- 1.0 MM THICK FACE FOR ROBUST CONNECTOR RETENTION AND GROUNDING.
- CUSTOM I/O CUTOUTS INCLUDED
- MAXIMUM FACE AREA AVAILABLE FOR CONNECTOR CUTOUTS
- ASSEMBLED AND READY TO ATTACH TO YOUR MODULE PCB

EXTRUDED ALUMINUM AND STAINLESS STEEL FACEPLATE ASSEMBLIES - AMC.0 REL 2.0

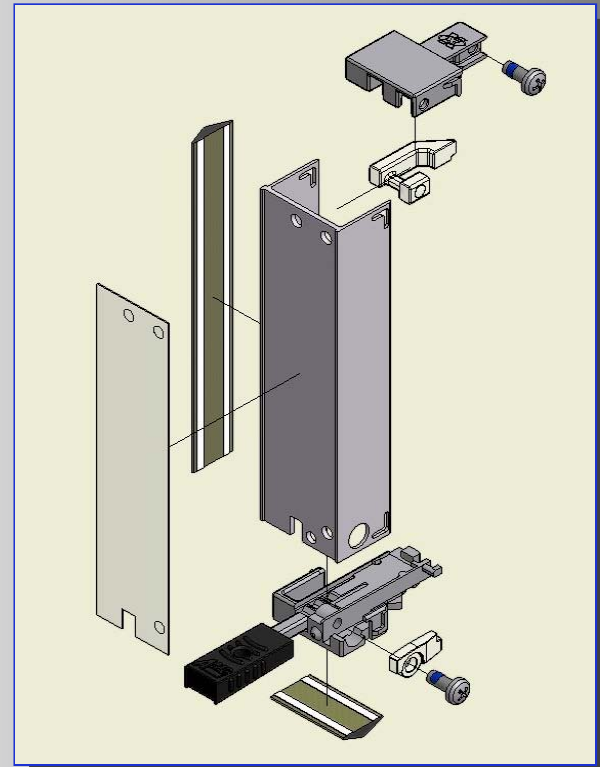
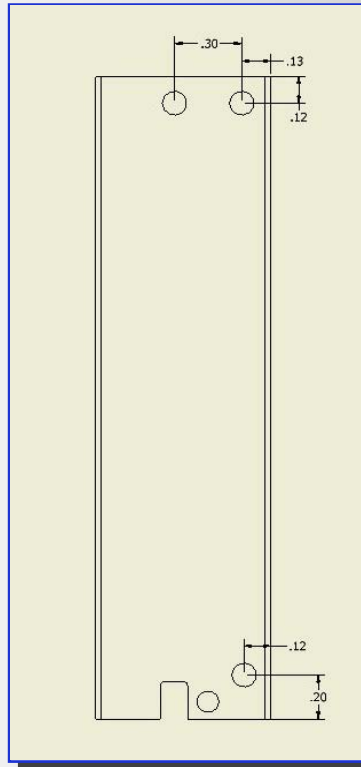

STAINLESS STEEL SPECIFICATIONS

- FACEPLATE - Stainless Steel
- FINISH - Clear Passivation
- DUAL LIGHT PIPE - Polycarbonate
- LIGHT PIPE HOUSING - Zinc-Alloy with Electroless Nickel
- PCB SCREWS - Stainless Steel with Locking Patch
- HOT SWAP LATCH HANDLE - Zinc-Alloy and Stainless Steel with Powder Coated Handle
- EMI GASKETS - Fabric over Foam
- CUSTOM OVERLAY - 0.25mm Velvet Matte Polycarbonate
- SPECIFICATION COMPLIANCE - PICMG AMC.0 Rel 2.0; UL94-V0; RoHS Compliant

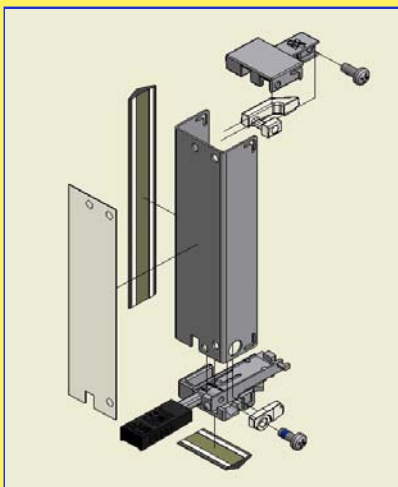

SIZES AND PART NUMBERS

