

REV	DESCRIPTION	DRW	APR	DATE
A	PRODUCTION RELEASE, ECO 1983	TM	JS	05/29/07

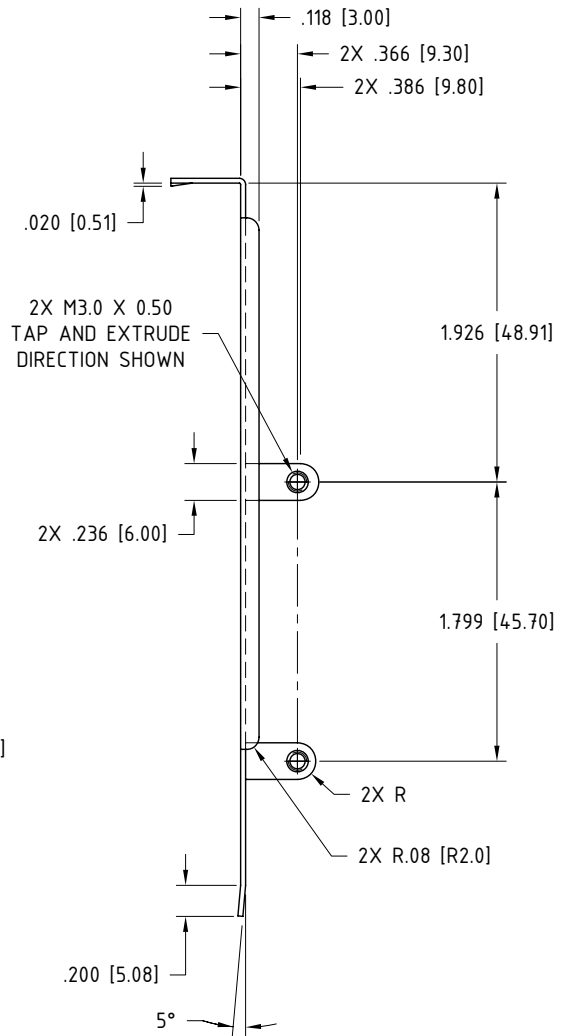
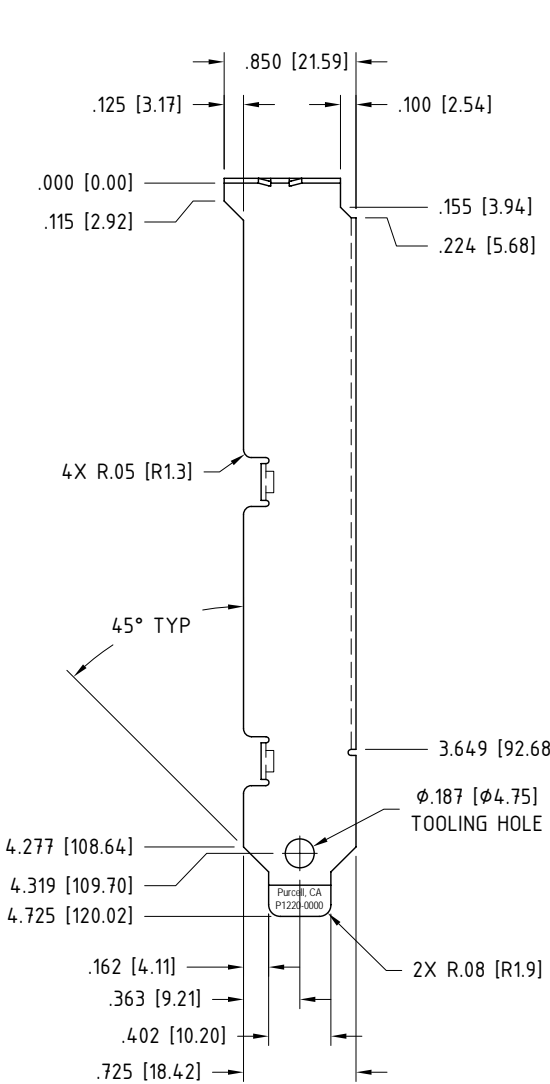
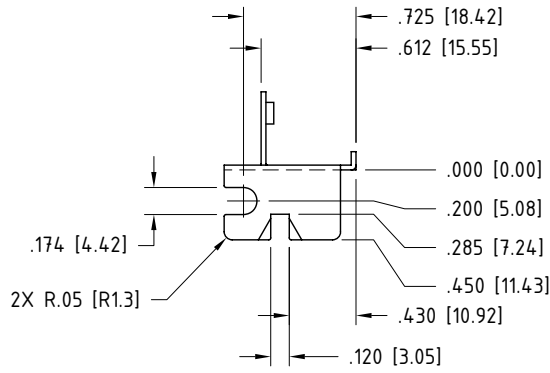

PROPRIETARY STATEMENT
 THIS DOCUMENT CONTAINS INFORMATION THAT IS PROPRIETARY TO PURCELL TECHNOLOGIES INC. REPRODUCTION, DISCLOSURE, OR USE OF THE CONTENTS OF THIS DOCUMENT IS EXPRESSLY PROHIBITED WITHOUT PRIOR WRITTEN AUTHORIZATION BY PURCELL TECHNOLOGIES INC.
 FORMAT DOCUMENT NO:
 QR300012 Rev A

CUSTOMER:
WEGENER

CUSTOMER P/N:
NONE

TOLERANCES
 STD ± .01
 RAD ± .01
 DIA ± .005
 MAT ± .002
 ANG ± 1°
 DIMS IN INCHES[MM]

MATERIAL:
 0.8mm THK CRS
FINISH:
 BRIGHT NICKEL
COSMETIC CLASS:
 CLASS C
COSMETIC INSPECTION:
 TABLE II
RoHS COMPLIANT (Y/N):
 YES
LEAD FREE (Y/N):
 YES

161 SAND CREEK ROAD
 BRENTWOOD, CA 94513
 PHONE (925) 513-4200
 FAX (925) 513-1370
 WWW.PURCELLTECH.COM

DESCRIPTION
 BRACKET, PCI, 2X TAB, RIB, BLANK

DRAWING NO. **P1220-0000** REV **A**

SCALE: 1:1 THIRD ANGLE PROJECTION SHEET 1 OF 1