

REV	DESCRIPTION	DRW	APR	DATE
A	PRODUCTION RELEASE	TM	JP	10.17.00
B	TAPPED HOLE LOCATION WAS .275"	TM	JP	12.01.00
C	REVERSE EXTRUDE DIRECTION, ECO 0207	TM	JP	03.09.01

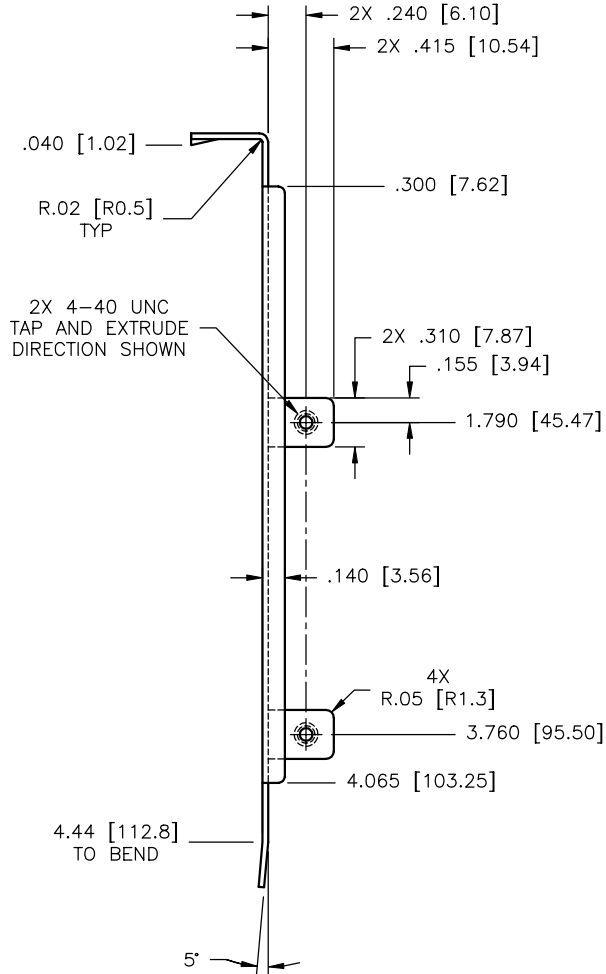
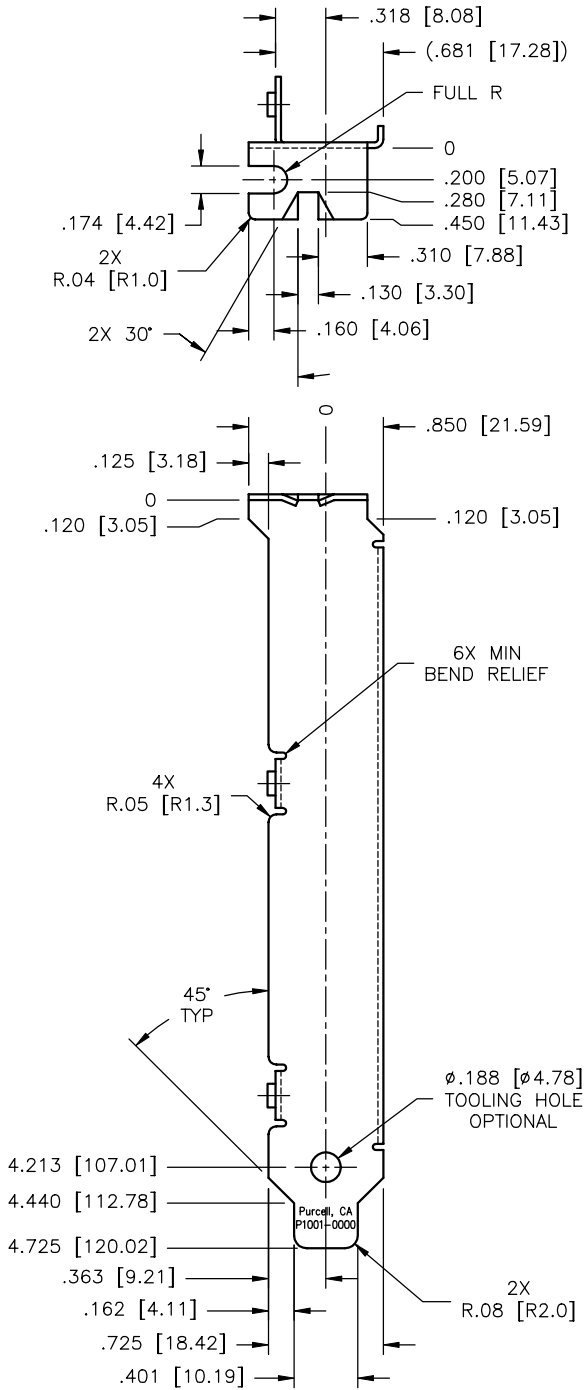

PROPRIETARY STATEMENT

THIS DOCUMENT CONTAINS INFORMATION THAT IS PROPRIETARY TO PURCELL BRACKETS INC. REPRODUCTION, DISCLOSURE, OR USE OF THE CONTENTS OF THIS DOCUMENT IS EXPRESSLY PROHIBITED WITHOUT PRIOR WRITTEN AUTHORIZATION BY PURCELL BRACKETS INC.

TOLERANCES

STD \pm .01
 RAD \pm .01
 DIA \pm .005
 MAT \pm .002
 ANG \pm 1°

DIMS IN INCHES[MM]

MATERIAL:

.035" THK CRS

FINISH:

BRIGHT NICKEL

APPROVAL:

JP

DRAWN:

TM

DATE:

10.17.00

SCALE:

4:5



275 CENTRAL TERRACE, STE. E
 BRENTWOOD, CA 94513
 PHONE (925) 513-4200
 FAX (925) 513-1370

WWW.PURCELLBRACKETS.COM

DESCRIPTION

BRACKET, PCI, 2X TAB 4-40,
 1X RIB, BLANK

DRAWING NO.

P1001-0000

REV

C

THIRD ANGLE PROJECTION

