

ATCA Handles

The standard ATCA ejector handle operates within the PICMG[®] 3.0 specification, providing latching security, hot-swap versatility and mechanical durability. Its unique design operates with a push button release and simple push to close. Handles are RoHS compliant.



ATCA EJECTOR HANDLE, TYPE 5 BLACK SHOWN

ATCA HANDLES		
DESCRIPTION	PART NUMBER	
ATCA EJECTOR HANDLE, TYPE 3 (BLACK)	P020-0000-3A (P020-B000-3A)	
ATCA EJECTOR HANDLE, TYPE 4 (BLACK)	P020-0000-4A (P020-B000-4A)	
ATCA EJECTOR HANDLE, TYPE 5 (BLACK)	P020-0000-5A (P020-B000-5A)	
ATCA EJECTOR HANDLE, TYPE 6 (BLACK)	P020-0000-6A (P020-B000-6A)	
ATCA COMPONENTS		
DESCRIPTION	PART NUMBER	ILLUSTRATION
ATCA HANDLE BUSHING (PCB THICKNESS)	P030-0001-00 (2.4mm) P030-0001-20 (2.2mm) P030-0001-40 (2.0mm) P030-0001-60 (1.8mm) P030-0001-80 (1.6mm)	
ATCA HANDLE MOUNTING HARDWARE SCREW: M2.5 X 6mm FLAT WASHER: M2.5	P9720 (SCREW) P030-0002-00 (WASHER)	
ATCA GASKET, 285mm FABRIC OVER FOAM pressure adhesive backed	EK1532T1122	

ATCA Handle & Hot-Swap Operation

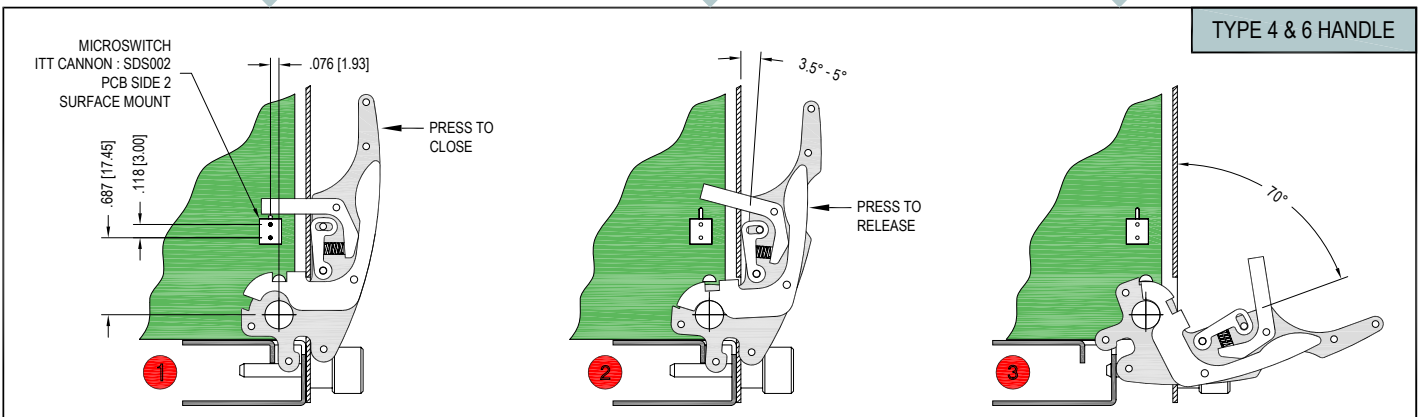
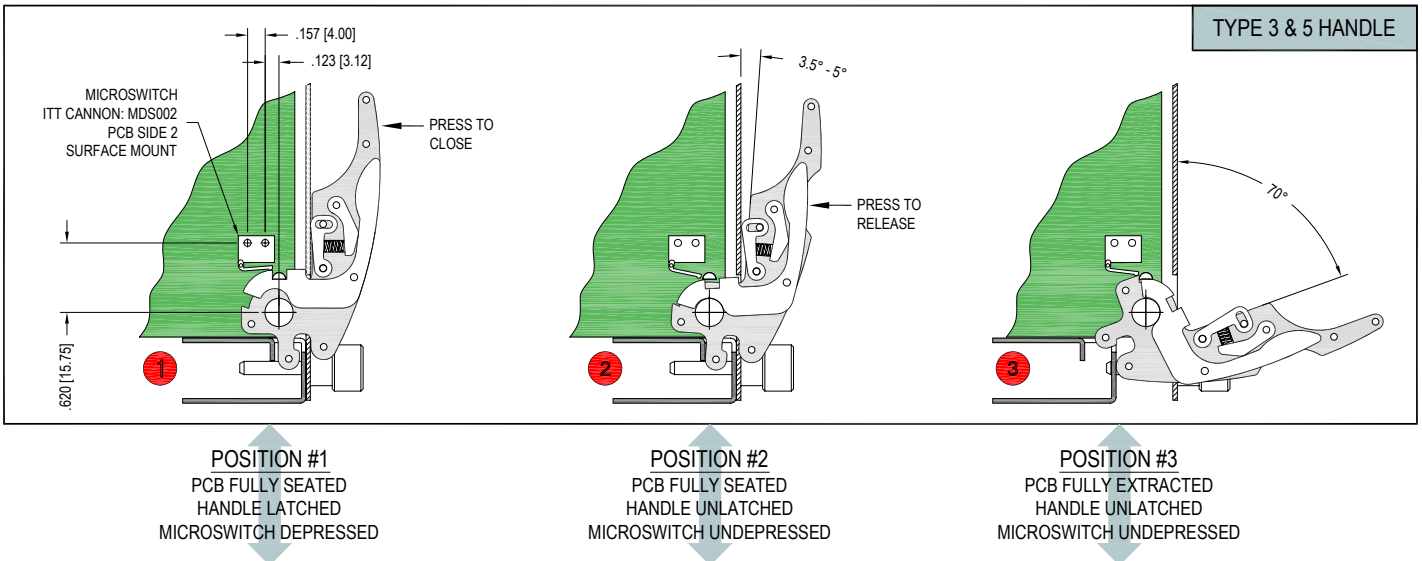

ATCA Panels

PICMG[®] 3.0 compatible ATCA panels and filler panels are constructed from 1mm thick 1010 steel nickel plated for corrosion resistance and electrical conductivity. Panels and all assembled components are RoHS compliant.

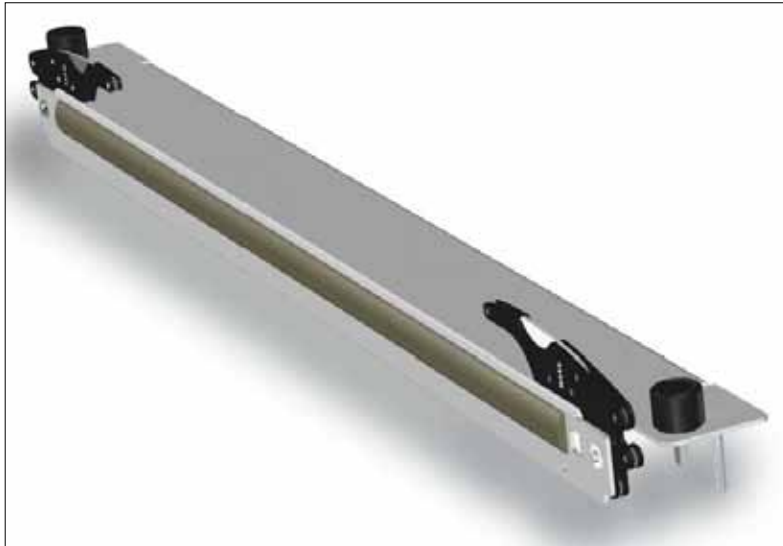

HATCHED AREAS INDICATE OVERLAY STAY OUT ZONES TO ENSURE PROPER EJECTOR HANDLE OPERATION

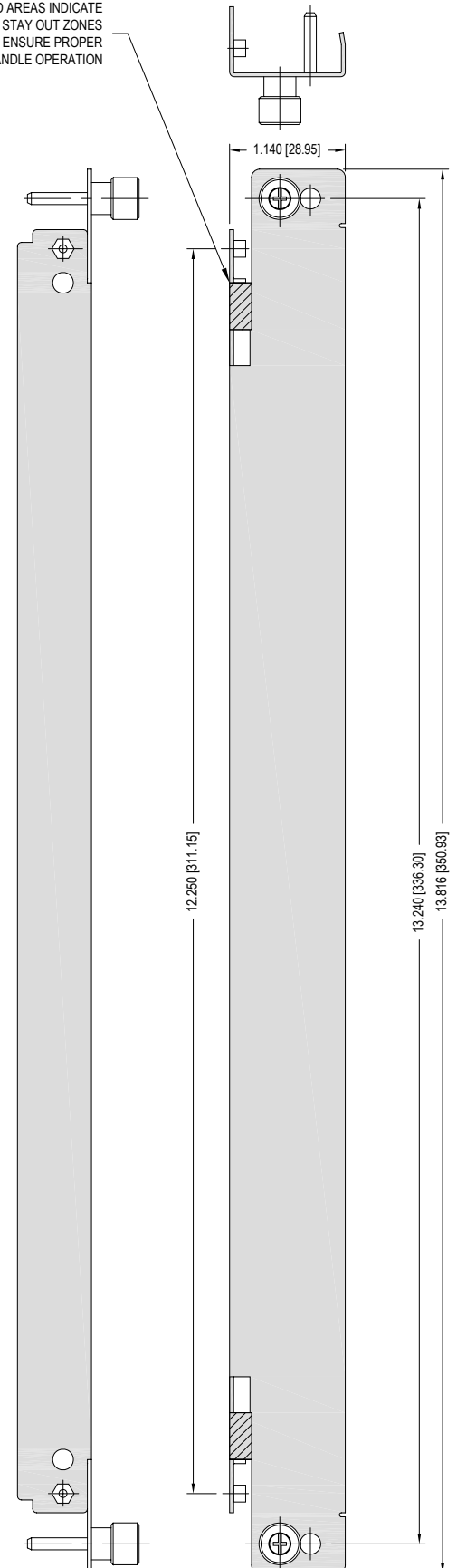

ATCA BLANK PANELS	
DESCRIPTION	PART NUMBER
ATCA PANEL, 8U X 6HP, SILVER HARDWARE	P010-0000-10
ATCA PANEL, 8U X 6HP, BLACK HARDWARE	P010-B000-10
ATCA FILLER PANEL, 8U X 6HP, SILVER HARDWARE	P010-0000-F0
ATCA FILLER PANEL, 8U X 6HP, BLACK HARDWARE	P010-B000-F0

ATCA Assembly & Kit Part Numbers

